



Intel® Dialogic® D/120JCT-LS Combined Media Board

The D/120JCT-LS board is a 12-port analog PCI board ideal for developing advanced communications applications that require multimedia resources. This high-performance, scalable product supports voice, fax, and software-based speech recognition processing in a single PCI slot, and provides 12 analog telephone interface circuits for direct connection to analog loop start lines.



Features and Benefits

Supports continuous speech processing, a flexible speech processing technology. When coupled with efficient drivers, this off-loads critical real-time signal processing in speech-enabled applications to onboard DSPs. It reduces system latency, increases recognition accuracy, and improves overall system response time for high-density speech solutions.

H.100 support ensures a single universal bus standard, allowing simplified expansion to the industry-standard CT Bus

Universal 32-bit PCI edge-connector for compatibility with 3.3 volt and 5.0 volt bus signals enables deployment in a wide variety of PCI chassis from popular manufacturers.

Support for Windows NT*, Windows 2000*, and Linux* operating systems ensure high reliability in multitasking environments.

Caller ID and global dial pulse detection (DPD) support advanced global communications solution.

Configure multiple boards in a single PCI chassis for easy and cost-effective system expansion.

Spring Ware downloadable signal and call processing firmware provides easy feature enhancement and field-proven performance.

PerfectDigit DTMF (touchtone) provides reliable detection during voice playback - lets callers "type-ahead" through menus.

Silence-compressed recording eliminates silence and preserves hard disk space.

Board Locator Technology eliminates confusing DIP switch or jumper settings and simplifies installation.

Supports Simple Network Management Protocol (SNMP) software used for remote CT board diagnostics/management.

Earth Recall capability provides support for switches in the UK in addition to complementing existing infrastructure.

Intel® NetMerge™ Converged Communications Server Software support facilitates multi-vendor application development.

Fully supports Japanese CID including the ability to detect polarity reversals while online.

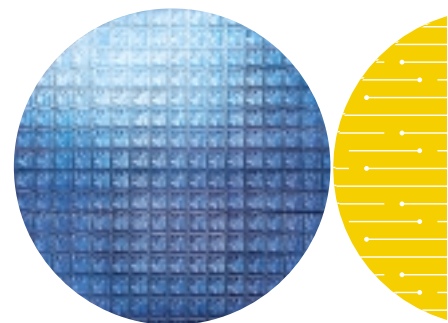

The D/120JCT-LS board is part of the next generation of Intel® Dialogic® analog PCI boards, offering the enhanced capabilities an evolving communications market segment demands. The product is ideal for advanced computer telephony (CT)-based communications applications that require multimedia resources. This high-performance, scalable CT product, based on Spring Ware technology, offers a rich set of advanced features in addition to supporting state-of-the-art digital signal processing (DSP) technology and signal processing algorithms, ensuring a competitive edge for your solutions.

Advanced features include new voice coders such as G.726 and GSM for complying with Voice Profile for Internet Messaging (VPIM) standards. Advanced features including software-based fax and speech recognition also let developers add robust enhancements without additional hardware. With the support of the industry-standard PCI bus architecture and the international standard CTR21 in a single board, developers can integrate the D/120JCT-LS board at a price and performance level previously unmatched in the communications industry.

With all these features and advanced technologies, the 12-port D/120JCT-LS PCI analog voice processing board is well suited as the principal building block for developing multimedia communications applications such as Web-enabled contact centers, unified messaging, and speech-enabled interactive media response (IMR) systems.

Spring Ware firmware also provides reliable DTMF detection, DTMF cut-through, and talk off/play off suppression over a wide variety of telephone line conditions.

Global dial pulse detection (DPD) algorithm, available as a software option for the D/41JCT-LS board, lets developers use the board in countries with limited touchtone telephone service. The Global DPD product can be optimized on a country-by-country basis to provide superior dial pulse detection.

Intel voice products offer a rich set of advanced features, including state-of-the-art DSP technology and signal processing algorithms, for building the core of any converged communications system. With industry-standard PCI bus expansion boards developers can integrate Intel voice products easily and cost effectively into exactly the type of system they require, with superior performance.

Configurations

Use the D/120JCT-LS board to build sophisticated CT systems with capabilities such as speech recognition, facsimile, and text-to-speech (TTS). The D/120JCT-LS board shares a common hardware and firmware architecture with other Intel CT Bus and SCbus based boards for maximum flexibility and scalability. Add features or grow the system while protecting your investment in hardware and application code. Applications can be easily ported to lower- or higher-line-density platforms with minimal modifications.

The D/120JCT-LS board provides 12 channels of call processing and loop start interfaces in a single PCI slot. The unique dual-processor architecture, comprised of DSPs and a general-purpose microprocessor, handles all telephony signaling and performs all DTMF (touchtone) and audio/voice signal processing tasks.

Downloaded firmware algorithms such as Spring Ware provide variable voice coding at 24 and 32 Kb/s ADPCM, and 48 and 64 Kb/s μ -law or A-law PCM. For advanced messaging applications, new low bit rate coders (GSM at 13 Kb/s and G.726 at 32 Kb/s) are also available. Sampling rates and coding methods are selectable on a channel-by-channel basis. Applications can dynamically switch the sampling rate and coding method to optimize data storage or voice quality as the need arises. Spring Ware firmware also reliable DTMF detection, DTMF cut-through, and talk-off/play-off suppression over a wide variety of telephone line conditions.

Applications

- Interactive media response
- Web-enabled contact center
- Unified messaging
- Speech-enabled auto-attendant

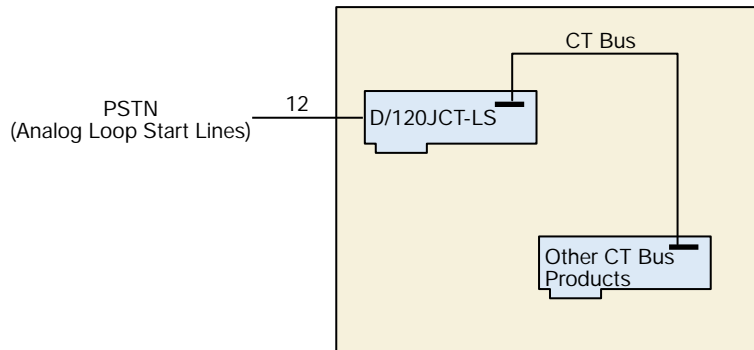

D/120JCT-LS Configuration Diagram

Offered as a software option, global dial pulse detection (DPD) converts rotary pulses to DTMF in countries that have limited touchtone telephone service. Global DPD is also optimized in several countries to provide superior dial pulse detection and conversion.

Software Support

The D/120JCT-LS board is currently supported by the Intel® Dialogic® System Release (SR) software and software development kits (SDKs) for the Windows NT* and Windows* 2000 operating systems and the SR software and SDKs for Linux* operating systems. These packages contain a set of tools for developing complex multichannel applications.

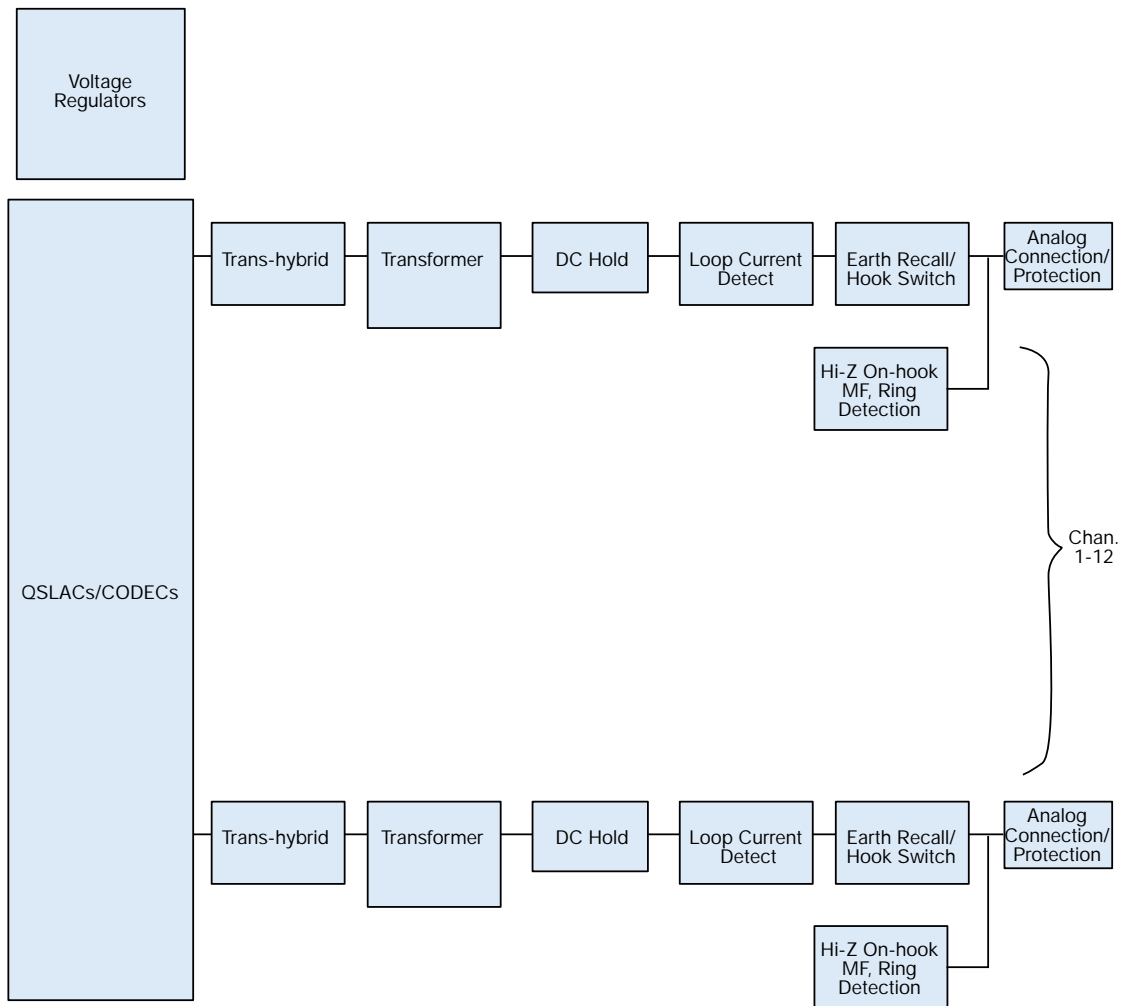

Functional Block Diagram

Functional Description

The D/120JCT-LS board connects 12 analog loop start telephone lines to 12 onboard call processing resources or to other resources via the CT Bus.

This board provides:

- Interference suppression
- Ring and on-hook/off-hook signaling control
- Tone detection and generation
- Digitization and playback of voice files

The signals from the 12 loop start telephone lines connected to the D/120JCT-LS board first pass through a telephone line interface that provides transient protection and electromagnetic interference (EMI) suppression (see daughterboard block diagram). These telephone line interfaces use reliable, solid-state hook switches (no mechanical contacts) and FCC-Part 68 Class A ring voltage and Class B ring frequency

circuitry. This FCC-approved ring detector is less susceptible to spurious rings created by random voltage fluctuations on the network. Each interface also incorporates circuitry that protects against high-voltage spikes and adverse network conditions and allows applications to go off-hook any time during ring cadence without damaging the board.

The telephone line interface applies the inbound signal including the ring and on-hook/off-hook signals to analog/digital inputs of a signal converter called a codec (COder/DECoder) that samples and digitizes these signals. These digitized signals are sent to a QSLAC chip where they are routed via the CT Bus either to an onboard Motorola® 56303 Onyx DSP or to an external resource on any of the 1024 CT Bus time slots. This enables the application to reroute calls to any added resource, such as speech recognition, facsimile, or text-to-speech (TTS).

Part of the D/120JCT-LS board's telephone interface includes an on-hook audio path that detects Caller ID information. Depending on the level of service offered by the local telephone provider, Caller ID can include the date, time, caller's telephone number, and the name of the person calling (in some enhanced Caller ID environments). The on-hook audio path can also detect touchtones while the line is on-hook. This capability lets developers use the D/120JCT-LS board behind PBXs that require on-hook touchtone detection for signaling.

When the onboard call processing resources are used, the network signals are extracted and passed to the onboard control processor, which can change channel status and communicate channel events to the application via a shared RAM and the host PC PCI bus.

The Motorola 56303 Onyx DSP processes the digitized voice data based on Spring Ware firmware loaded in code/data RAM. Each Motorola 56303 Onyx DSP performs the following signal analysis and operations.

On the incoming data:

- Applies automatic gain control (AGC) to compensate for variations in the level of the incoming audio signal
- Applies an Adaptive Differential Pulse Code Modulation (ADPCM), Pulse Code Modulation (PCM) algorithm, G.726 32 Kb/s coding or GSM, to compress the digitized voice and save disk storage space
- Detects the presence of tones (DTMF, MF, or an application-defined, single or dual tone)
- Detects silence to determine whether the line is quiet and the caller is not responding

For outbound data:

- Expands stored, compressed audio data for playback
- Adjusts the volume and rate of speed of playback upon application or user request
- Generates tones — DTMF, MF, or any application-defined general-purpose tone

The dual-processor combination also performs the following outbound dialing and call progress monitoring:

- Transmits an off-hook signal to the telephone network
- Dials out (places an outbound call)
- Monitors and reports results: line busy or congested; operator intercept; ring, no answer; or if the call is answered, whether answered by a person, an answering machine, a facsimile machine or a modem

When recording speech, the Motorola 56303 Onyx DSP can use digitizing rates from 24 to 64 Kb/s as selected by the application for the best speech quality and most efficient storage. The digitizing rate is selected on a channel-by-channel basis and can be changed each time a record or play function is initiated. The DSP-processed speech is transmitted by the control processor to the host PC for disk storage. The D/120JCT-LS board can record incoming signals with the telephony interface in either the high-impedance on-hook state or the normal off-hook state. When replaying a stored file, the processor retrieves the voice information from the host PC and passes it to the Motorola 56303 Onyx DSP, which converts the file into digitized voice. The DSP sends the digitized voice responses to the codec, which is controlled by three QSLAC chips. The codec converts the digitized voice into analog voice and sends the voice response to the caller via the telephone line interface.

Although this product is capable of recording incoming signals in an on-hook state, applications such as call logging should use the D/160SC-LS-HiZ (ISA form factor), which is specifically designed for analog high-impedance recording.

When the system is initialized, Spring Ware firmware is downloaded from the host PC to the board. Spring Ware controls all board operations and gives the board all of its intelligence and enables easy feature enhancements and upgrades.

The onboard control processor controls all operations of the D/120JCT-LS board via a local bus and interprets and executes commands from the host PC. This processor handles real-time events, manages data flow to the host PC to provide faster system response time, reduces PC host processing demands, processes DTMF and telephony signaling before passing them to the application, and frees the Motorola 56303 Onyx DSPs to perform signal processing. Communication between the processor and the host PC is via shared RAM that acts as an input/output buffer and thus increases the efficiency of disk file transfers. This RAM interfaces to the host PC via the PCI bus. All operations are interrupt-driven to meet the demands of real-time systems. The Board Locator Technology circuit operates in conjunction with a rotary switch that eliminates the need to set confusing jumpers or DIP switches.

Technical Specifications

Number of ports	12
Maximum boards/operating system	8 (Linux, Windows NT, Windows 2000). Number may be limited by application and system performance.
Analog network interface	Onboard loop start interface
Resource sharing bus	CT Bus
Control microprocessor	Intel® 80486 GXSF running at 32.768 MHz with 2 MB SDRAM
Digital signal processors	Two Motorola* DSP 56303 (Onyx) @ 100 MHz, 24-bit, each with 256 K word private SRAM

Host Interface

Bus compatibility	PCI compatible (complies with PCISIG Bus Specification, Rev. 2.2)
Bus speed	33 MHz maximum
Bus mode	32-bit
Shared memory	32 KB to 64 KB page
Interrupt level	One IRQ is shared by all D/120JCT-LS boards
I/O ports	None

Telephone Interface¹

Trunk type	Loop start. Ground start for inbound applications with AC ringing.
Impedance	600 Ohms nominal
Loop current range	20 mA to 60 mA, (Euro) 20 mA to 120 mA, polarity insensitive
Ring detection	40 Vrms to 130 Vrms, 15.3 Hz to 68.0 Hz
Echo return loss	17 dB min. (at country impedance)
Crosstalk coupling	> -75 dB
Speech digitization	64 Kb/s, μ -law PCM (companding to ADPCM performed in Spring Ware)
Frequency response	300 Hz to 3400 Hz \pm 3 dB
Connector	RJ-25, 6-port, 6-position

Environmental Requirements

+5 VDC	1.2 A
+12 VDC	200 mA
-12 VDC	80 mA max.
Operating temperature	0°C to +50°C
Form factor	Universal slot (5 V or 3.3 V) PCI long card 12.28 in. (31.2 cm) long 4.2 in. (10.67 cm) high

Safety and EMI Certifications

United States	UL: 1950
Canada	CSA: 225 (by UL)
	For specific country approval designation, see the Intel Communications Systems Products Global Product Approvals listing on the Intel Web site or contact your Intel technical sales representative
Estimated MTBF	154,000 hours per Bellcore Method
Warranty	Intel® Telecom Products Warranty Information at http://www.intel.com/network/csp/products/3144web.htm

¹ Average speech mandates +16 dB peaks above average and preserves -13 dB valleys below average.

Spring Ware Firmware Technical Specifications

Facsimilie

Fax compatibility	ITU-T G3 compliant (T.4, T.30) ETSI NET/30 compliant
Maximum data rate	14,400 b/s (v.17) send 9600 b/s (v.29) receive
Variable speed selection	Automatic step-down to 12,000 b/s, 9600 b/s, 7200 b/s, 4800 b/s, and lower
Transmit data modes	Modified Huffman (MH) Modified Read (MR)
Receive data modes	MH, MR
File data formats	Tagged Image File Format (TIFF/F) for transmit/receive MH and MR
ASCII-to-fax conversion	Host-PC-based conversion Direct transmission of text files All Windows* fonts supported Page headers generated automatically
Error correction	Detection, reporting, and correction of faulty scan lines
Image widths	8.5 in. (215 mm) 10.0 in. (255 mm) 11.9 in. (303 mm)
Image scaling	Automatic horizontal and vertical scaling between page sizes
Polling modes	Normal Turnaround
Image resolution	Normal (203 pels/in. × 98 lines/in.) (203 pels/2.54 cm × 98 lines/2.54 cm) Fine (203 pels/in. × 196 lines/in.) (203 pels/2.54 cm × 196 lines/2.54 cm)
Fill minimization	Automatic fill bit insertion and stripping

Audio Signal

Receive range	-40 dBm to -7 dBm nominal, configurable by parameter [†]
Automatic gain control	Application can enable/disable. Above -22 dBm results in full-scale recording, configurable by parameter. [†]
Silence detection	-40 dBm nominal, software adjustable [†]
Transmit level (weighted average)	-9.5 dBm nominal, configurable by parameter [†]
Transmit volume control	40 dB adjustment range, with application-definable increments and legal limit cap

Frequency Response

24 Kb/s	300 Hz to 2600 Hz ±3 dB
32 Kb/s	300 Hz to 3400 Hz ±3 dB
48 Kb/s	300 Hz to 2600 Hz ±3 dB
64 Kb/s	300 Hz to 3400 Hz ±3 dB

Audio Digitizing

13 Kb/s	GSM @ 8 kHz sampling
24 Kb/s	OKI® ADPCM @ 6 kHz sampling
32 Kb/s	OKI® ADPCM @ 8 kHz sampling
32 Kb/s	G.726 @ 8 kHz sampling
48 Kb/s	μ-law PCM @ 6 kHz sampling
64 Kb/s	μ-law PCM @ 8 kHz sampling
Digitization selection	Selectable by application on function call-by-call basis
Playback speed control	Pitch controlled Available for 24 Kb/s and 32 Kb/s data rates Adjustment range: ±50% Adjustable through application or programmable DTMF control

Spring Ware Firmware Technical Specifications (cont.)

DTMF Tone Detection

DTMF digits	0 to 9, *, #, A, B, C, D per Bellcore LSSGR Sec 6
Dynamic range	-38 dBm to -3 dBm per tone, configurable by parameter ¹
Minimum tone duration	40 ms, can be increased with software configuration
Interdigit timing	Detects like digits with a >40 ms interdigit delay Detects different digits with a 0 ms interdigit delay
Twist and frequency variation	Meets Bellcore LSSGR Sec 6 and EIA 464 requirements
Noise tolerance	Meets Bellcore LSSGR Sec 6 and EIA 464 requirements for Gaussian, impulse, and power line noise tolerance
Cut-through	Local echo cancellation permits 100% detection with a >4.5 dB return loss line
Talk off	Detects less than 20 digits while monitoring Bellcore TR-TSY-000763 standard speech tapes (LSSGR requirements specify detecting no more than 470 total digits). Detects 0 digits while monitoring MITEL speech tape #CM 7291.

Global Tone Detection

Tone type	Programmable for single or dual
Max. number of tones	Application-dependent
Frequency range	Programmable within 300 Hz to 3500 Hz
Max. frequency deviation	Programmable in 5 Hz increments
Frequency resolution	± 5 Hz. Separation of dual-frequency tones is limited to 62.5 Hz at a signal-to-noise ratio of 20 dB.
Timing	Programmable cadence qualifier, in 10 ms increments
Dynamic range	Programmable, default set at -6 dBm to -3 dBm per tone

Global Tone Generation

Tone type	Generate single or dual tones
Frequency range	Programmable within 200 Hz to 4000 Hz
Frequency resolution	1 Hz
Duration	10 ms increments
Amplitude	-43 dBm to -3 dBm per tone, programmable

MF Signaling

MF digits	0 to 9, KP, ST, ST1, ST2, ST3 per Bellcore LSSGR Sec 6, TR-NWT-000506 and CCITT Q.321
Transmit level	Complies with Bellcore LSSGR Sec 6, TR-NWT-000506
Signaling mechanism	Complies with Bellcore LSSGR Sec 6, TR-NWT-000506
Dynamic range for detection	-25 dBm to -3 dBm per tone
Acceptable twist	6 dB
Acceptable frequency variation	Less than ±1 Hz

Spring Ware Firmware Technical Specifications (cont.)

Call Progress Analysis

Busy tone detection	Default setting designed to detect 74 out of 76 unique busy/congestion tones used in 97 countries as specified by CCITT Rec. E., Suppl. #2. Default uses both frequency and cadence detection. Application can select frequency only for faster detection in specific environments.
Ring back detection	Default setting designed to detect 83 out of 87 unique ring back tones used in 96 countries as specified by CCITT Rec. E., Suppl. #2. Uses both frequency and cadence detection.
Positive voice detection accuracy	>99% based on tests on a database of real world calls in North America. Performance in other markets may vary.
Positive voice detection speed	Detects voice in as little as 1/10th of a second
Positive answering machine detection accuracy	>85% based on application and environment
Fax/modem detection	Pre-programmed
Intercept detection	Detects entire sequence of the North American tri-tone. Other intercept tones sequences can be programmed.
Dial tone detection before dialing	Application enable/disable Supports up to three different user-definable dial tones Programmable dial tone drop out debouncing

Tone Dialing

DTMF digits	0 to 9, *, #, A, B, C, D per Bellcore LSSGR Sec 6, TR-NWT-000506
Frequency variation	Less than ± 1 Hz
Rate	10 digits/s maximum, configurable by parameter [†]
Level	-4.0 dBm per tone, nominal, configurable by parameter [†]

Pulse Dialing

10 digits	0 to 9
Pulsing rate	10 pulses/s, nominal 20 pulses/s for Japan, configurable by parameter [†]
Break ratio	60% nominal, configurable by parameter [†]

Analog Caller Identification

Applicable standards	Bellcore TR-TSY-000030 Bellcore TR-TSY-000031 TAS T5 PSTN1 ACLIP: 1994 (Singapore)
Modem standard	Bell 202 or V.23, serial 1200 bits/sec (simplex FSK signaling)
Receive sensitivity	-48 dBm (-50 dBv) to -1 dBm
Noise tolerance	Minimum 18 dB SNR over 0 to -48 dBm dynamic range for error-free performance
Data formats	Single Data Message (SDM) and Multiple Data Message (MDM) formats via API calls and commands
Line impedance	AC coupled 600 Ohm (@ 1.8 kHz) termination during Caller ID on-hook detection interval
Message formats	ASCII or binary SDM, MDM message content

Analog Display Services Interface (ADSI)

FSK generation per Bellcore TR-NWT-000030 CAS tone generation and DTMF detection per Bellcore TR-NWT-001273
--

[†] Analog levels: 0 dBm0 corresponds to a level of +3 dBm at tip-ring analog point. Values vary depending on country requirements; contact your account manager.

Hardware System Requirements

Intel® Pentium® processor based (PCI) bus or compatible computer. Operating system hardware requirements vary according to the number of channels being used.

Additional Components (with Item Market Names)

- Multidrop CT Bus cables (CBLCTB68C3DROP, CBLCTB68C4DROP, CBLCTB68C8DROP, CBLCTB68C12DROP, CBLCTB68C16DROP)
- CT Bus/SCbus adapter (CTBUSTOSCBUSADP)
- SCbus terminator kits (1SCBUS1TERMKIT, 2SCBUS1TERMKIT, 3SCBUS1TERMKIT)
- Six-strand RJ-type cable (preferred solution for customers using all 12 channels) (RJ-11 connectors to standard 50-pin Amphenol connector) (CBLD120PCI25PP) plus breakout box (BOB25POSJ11)
 - Support for both US and Euro cards
 - One cable and one breakout box per board required
- “Two-into-one” conversion cable (preferred solution for customers using only one or two channels)
 - Six cables per board required
 - US (CBLRJ14TORJ11YA) and Euro (CBLD120PCIYADAP) cables sold separately

To learn more, visit our site on the World Wide Web at <http://www.intel.com>.

1515 Route Ten
Parsippany, NJ 07054
Phone: 1-973-993-3000

INFORMATION IN THIS DOCUMENT IS PROVIDED IN CONNECTION WITH INTEL® PRODUCTS. NO LICENSE, EXPRESS OR IMPLIED, BY ESTOPPEL OR OTHERWISE, TO ANY INTELLECTUAL PROPERTY RIGHTS IS GRANTED BY THIS DOCUMENT. EXCEPT AS PROVIDED IN INTEL'S TERMS AND CONDITIONS OF SALE FOR SUCH PRODUCTS, INTEL ASSUMES NO LIABILITY WHATSOEVER, AND INTEL DISCLAIMS ANY EXPRESS OR IMPLIED WARRANTY, RELATING TO SALE AND/OR USE OF INTEL PRODUCTS INCLUDING LIABILITY OR WARRANTIES RELATING TO FITNESS FOR A PARTICULAR PURPOSE, MERCHANTABILITY, OR INFRINGEMENT OF ANY PATENT, COPYRIGHT OR OTHER INTELLECTUAL PROPERTY RIGHT.

Intel products are not intended for use in medical, life saving, life sustaining, critical control or safety systems, or in nuclear facility applications.

Intel may make changes to specifications, product descriptions, and plans at any time, without notice.

Intel, Intel Dialogic, Intel386, Intel486, Pentium, and the Intel logo are trademarks or registered trademarks of Intel Corporation or its subsidiaries in the United States and other countries.

*Other names and brands may be claimed as the property of others.

